



Datenblatt - Fiche technique - Data sheet

26.99.0347



VALUE Kat. 5e 19"-Patchpanel, 24P, ungeschirmt, lichtgrau

VALUE Panneau de brassage Cat.5e, 24P, non blindé, gris clair

VALUE Cat.5e 19" Patch Panel, 24 Ports, UTP, light grey

VALUE Cat.5e Patch Panel 24P, STP, I.grey

REVISION RECORD			
REV.	CONTENT	MOD.	DATE
△	NEW PUBLISHING		

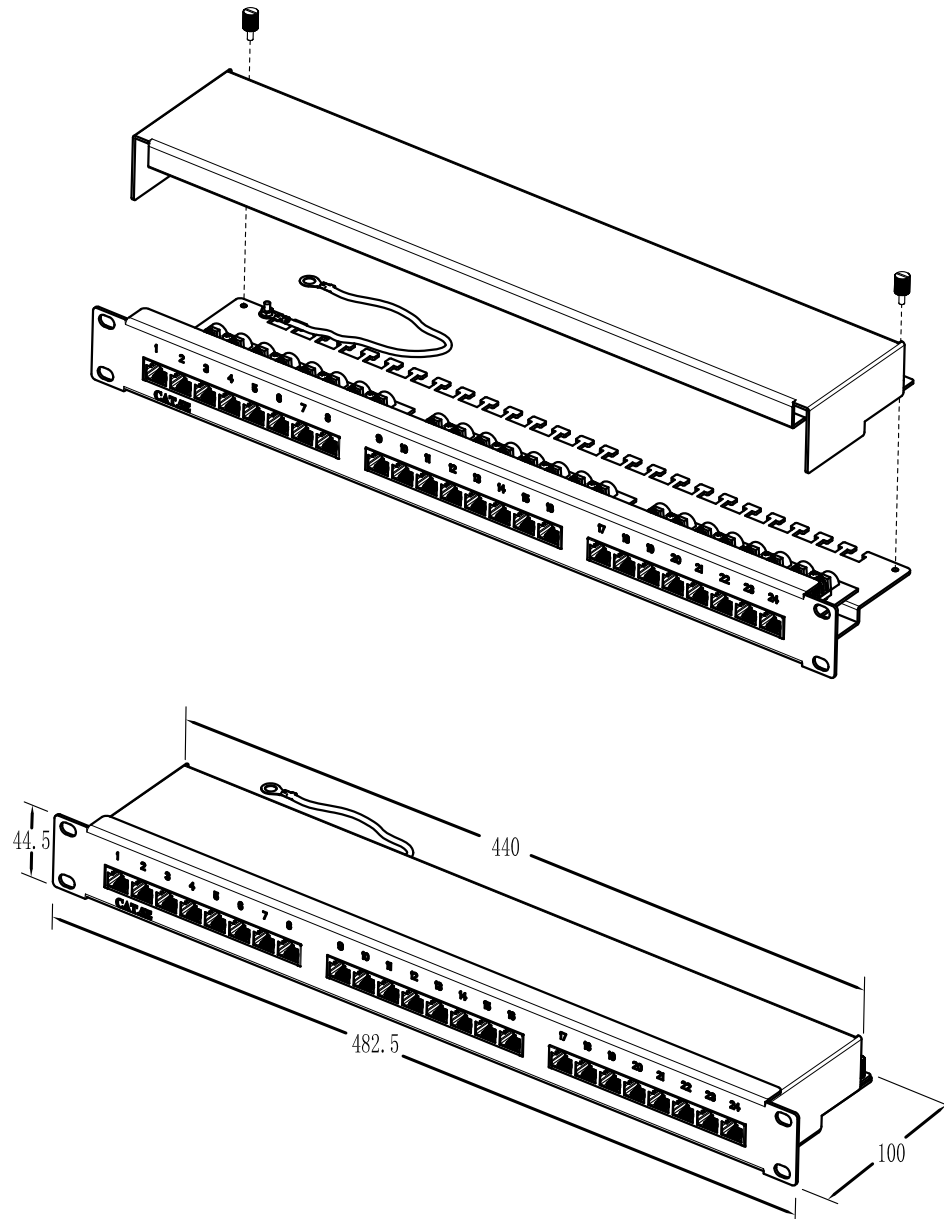

Performance:

Meet or Exceed Cat.5E EIA/TIA 568B.2 Standard.

Materials:

Bottom Panel : 1.5mm thickness Metallic Panel(SECC)/RAL7035
 Upper Panel Cover : 1.0mm thickness Metallic Panel(SECC)/RAL7035
 RJ45 Jack Shielded Case: 0.25mm thickness Brass with Ni Plated
 RJ45 Jack Housing-Fireproof PBT UL-94V0
 RJ45 Jack Insert: Housing-Fireproof PBT UL-94V0
 Contact-8P8C Phosphor bronze with 6 to 50U" gold plated
 PCB : FR-4/1.6mm UL-94V0
 IDC Body : Fireproof PC/ABS UL-94V0/With Colour Coded Printing T568A/B
 IDC Pin : Phosphor bronze & Tinned
 IDC Terminal: For 22-26 AWG Cable

Electrical Specifications:

Insulation Resistance: 500M ohms (min.)
 Contact Resistance: 20m ohms (max.)
 Current Rating : 1.5 Amps
 DC Resistance: 0.1 ohms(max.)
 Withstanding Voltage : 1000 VAC RMS @ 60Hz/ 1 min

Mechanical Specifications:

IDC Punch Down Cycle : Over 25 Cycles (min.)
 RJ-45 Jack Insertion Cycle : Over 200 Cycles (min.)

Accessory:

- 1.M3 Screw Set, For Pre-Assembled Ground Wire
- 2.Cable Tie(75X1.9mm)X24Pcs
- 3.Instruction Sheet
- 4.Knurled Screws

0.	Cat.5e Patch Panel	26.99.0347				
NO.	NAME OF PART	NO. OF PART	Q'TY	MATERIAL	NOTES	
DES.	XHF	DATE 09/3/31	UNITS	mm	FIRST ANGLE PROJECTION	
CHK.	DATE		SIZE	A4		
APP.	DATE		SCALE	1:4	DWG NO.	
Rotronic Co.,Ltd					TITLE	Cat.5e Patch Panel