

ROLINE Digital Signage Stand, Advertising, silver

Product No.	17.03.1251	roline Designed for Professionals
Manufacturer	ROLINE	
Manufacturer No.	17.03.1251	

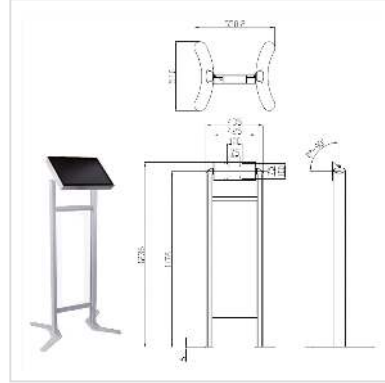
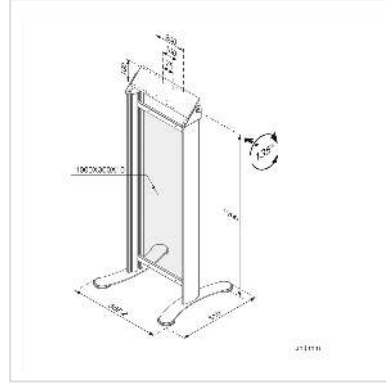

- How can an a digital signage stand benefit your business? There are a lot of possibilities, and they can be used across a wide variety of settings including retail stores & trade shows. That enables users to take projects and presentations on the road with ease.
- Digital Signage stands turn a tablet into a versatile workstation or customer information center. Pre-load apps and software for customers to use that is tailored to your business.

For what types of businesses are these products commonly used?

- Hotels - for guests to check in/out or to request room accommodations
- Restaurants & Food Service Locations - reservation of seating or food order
- Trade Shows & Convention Centers
- Retail Stores - for shoppers to participate in giveaways or learn more about the range of offered products
- Car Dealerships - for customers to see individual features on new models, check in for vehicle maintenance services or queue up to meet with a dealer
- Designed with heavy duty extruded alloy

Technical specifications

Manufacturer	ROLINE
Product group	LCD-Monitor arms
Product type	Monitor stand
Colour	silver
Maximum weight capacity	10 kg

Quantity of pivots	1
Adjustments	Adjustable spring gauge
Inclinable	yes
Height adjustable	yes
Number of monitors	1
VESA 100 x 100 mm	yes
VESA 200 x 100 mm	yes
Material group	metal
Technical particularity	Height: 1200 mm
Height	1200 mm
Width	558 mm
Depth	510 mm
Weight	12 kg
Height of packaging (single piece)	170 mm
Width of packaging (single piece)	290 mm
Depth of packaging (single piece)	1140 mm
Package weight (single piece)	14.3 kg